

## 5.56x45 DRONEBLASTER (GP01)

### GENERAL INFORMATION

The anti-drone ammunition is manufactured at AB Giraitės ginkluotės gamykla (GGG). The ammunition is designed to destroy small drones at close range. This ammunition is compatible with standard military automatic and semi-automatic weapons.

When it comes out of the muzzle, the shell of the bullet falling apart under the influence of centrifugal force, releasing fragments into the object, thus increasing the probability of hitting compared to a standard bullet.

Not suitable for shooting using silencers.

### TECHNICAL SPECIFICATIONS

#### 1. Table. Technical specifications

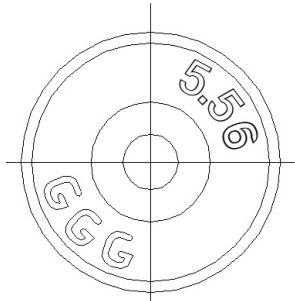
		<b>Caliber</b>		5.56x45
		<b>Fragmentation</b>		Brass cylinders 6pcs
		<b>Total length</b>	mm	57.4
		<b>Total weight</b>	g	11.4±0.6
		<b>Bullet</b>	type	Multifragment fragile bullet
		<b>Bullet weight</b>	gr	55
			g	3.6
		<b>Bullet extraction</b>	N	≥ 50 N
		<b>Case material</b>		CuZn30
		<b>Case length</b>	mm	44.70 -0.25
		<b>Propellant</b>	type	Double base, smokeless
			type	BOXER
		<b>Primer</b>		Percussion, non corrosive, non mercuric

### BALLISTIC PROPERTIES

Initial velocity, m/s	900
Maximum horizontal range, m	300
Maximum vertical range, m	200
Most effective range, m	50
Dispersion at 50 m, (cm)	~150

### MARKING

Minimum marking of cartridge and it's packaging is done in accordance with STANAG 2953 (AOP – 2C):

### PRODUCT INFORMATION SHEET

 <small>GIRAITĖS GINKLUOTĖS GAMYKLA PASSION. PERFORMANCE. PRECISION.</small>	CARTRIDGE 5.56x45			CALIBER: <b>5.56x45</b>	SHEET: 1/2
	DRAWN BY: K. Buzas	CHECKED BY: R. Bendaravičius	DATE: 2026.06.01	<b>556 PIS GP01</b>	<b>00</b>

**- Stamped on the base of cartridge case:**

- Manufacturer's initials
- Caliber

**- Marking on the internal carton box:**

- Quantity of cartridges in the box
- Caliber
- Type of cartridges
- Lot number
- Recycle marks of manufacturer

**- Marking on the external carton or metal box:**

- Quantity of cartridges in the box
- Type of cartridges
- Caliber
- Lot number
- Net weight
- Net explosive quantity
- Gross weight
- Volume
- Proper chipping name
- Certification number of the outer box
- UN number
- Explosive hazard orange mark
- Recycle marks of package
- Serial number label of box

**PACKAGING**

5.56x45 cartridges supplied in either outer carton or metal M2A1 boxes which are palletized. The boxes and pallets should be marked according to the requirements of the customer.

**2. Table. Cartridges packaging and units**

Number of packing	Palletization option	PACKING OPTION	UNITS			
			Quantity of cartridges	Dimension, mm	Net weight, kg	Gross weight, kg
1		Internal carton box	50	97 x 58 x 43.5	–	0.6
		External Metal box M2A1	1000	305.6 x154.8 x190.5	12.0	15.0
	1.1	EUR pallet	48000	920x1250x520	576.0	749.0
	1.2	EUR pallet	56000	1080x1250x520	672.0	873.0

**SHIPPING AND STORAGE DATA**

Proper shipping name – Cartridges for weapons, inert projectile  
 Hazard classification code – 1.4 S  
 UN serial number – UN 0012

**PRODUCT INFORMATION SHEET**

 <small>GIRAITES GINKLUOTES GAMYKLA PASSION. PERFORMANCE. PRECISION.</small>	CARTRIDGE 5.56x45			CALIBER: <b>5.56x45</b>	SHEET: 2/2
	DRAWN BY: K. Buzas	CHECKED BY: R.Bendaravičius	DATE: 2026.06.01	<b>556 PIS GP01</b>	<b>00</b>